

T-Frame™ for *CompactPCI*™

8-Slot *CompactPCI*™ Test and Development System

Description

The T-Frame™ for CompactPCI is a versatile 8-slot benchtop system combining unique design and features; creating the ideal platform for board level and software development, manufacturing and test.

T-Frame's patented open-frame design provides unrestricted access to installed boards, eliminating the need for performance robbing extender cards. The T-Frame™ includes comprehensive monitoring of all backplane voltages, current and exhaust air temperature. The front panel interface displays these monitor outputs and includes temperature, fan speed, and voltage control, including +5 and +3.3 volt margining. The 8-slot 64 bit backplane is hot-swap compatible and supports standard 3U or 6U boards. System slot is left justified to provide full access to the component side of installed boards. Two power options are available including single or dual 350 watt plugging power supplies, allowing hot swap power simulation, N+1, or 700 watt operation. Power supplies may be installed in either the front or rear cardcage, further improving accessibility. Fans are adjustable to full or half speed and automatically turn-off when not in use to reduce noise. T-Frame's steel and aluminum construction make it rugged yet easily portable. Tracewell's rigid steel cardcage eliminates the flex common to conventional extruded rail designs and is fully IEEE 1101.10/11 compliant. The rear I/O cardcage is adjustable for a wide range of board depths. Other conveniences include a tilt base, removable side access covers, recessed carrying handles, and internal 3.5" peripheral bay.

T-Frame™ for CompactPCI solves the problem of accessibility, measurement and control during development, thereby reducing design cycles and time to market.



T-Frame™ US Patent 5,416,427

Features

- Patented open-frame design eliminates extender boards
- Voltage, current and temperature monitoring
- Margin control for +5 and +3.3 volt outputs
- Hot-Swap compatible per PICMG 2.1
- 350 watt, N+1, or 700 watt operation
- Plugging power supplies with PFC and hot-swap
- IEEE 1101.10/11 compliant steel subracks eliminate flex
- Adjustable rear cardcage for 60, 80, and 100mm boards



ISO 9001
certified

Physical

Construction: Sheet aluminum, 5052-H32 alloy; sides (0.250"), top and bottom covers (0.062"), base (0.188")
Sheet steel, ASTM A366; front and rear cardcages (0.060")
Aluminum extrusion, 6101-T6 alloy; cardcage front profile

Plastics: Cardguide, snap-in, 0.062" pcb, white nylon, UL94V-2 material
Cardguide inlet, snap-in, 0.062" pcb, neutral nylon, UL94V-0 material
Adjustment knobs, black polycarbonate, UL94HB material
Tinted view windows, gray polycarbonate, UL94HB material

Cardcage: **Front:** 6U x 160mm, 8-slots, IEEE 1101.10; **Rear:** 6U x 80mm, -slots, IEEE 1101.11, adjustable for 60, 80, and 100mm boards

Dimensions: 15.60"D (396 mm) 14.37"W (365 mm) 16.83"H (428 mm)

Weight: 34 lbs. (74.8 kg) with one power supply (PS1)
37.5 lbs. (82.5 kg) with two power supplies (PS2)

Finish: Textured paint, T-Frame light gray per Sherwin Williams F63TXA0819; all exterior surfaces. All other aluminum is brushed gold chromate per MIL-STD 5541, steel is bright zinc plate

Accessories: Hardware kit provided which includes (8) +5.0 (brilliant blue) and +3.3V (cadmium yellow) backplane I/O keys, (2) I/O jumpers, and (1) drive power harness; Four removable side panels also provided

Backplane

Bus Structure: cPCI 32/64 bit, system slot left

Assembly: SMT/press-fit assembly

Layer count: 8 layers

Control: PRST#, DEG#, FAL#, return and remote sense (+5, +3.3, +/-12VDC)

PCB construction: FR4 epoxy-glass laminate, multilayer, all-stripline, SMOBC, silkscreen on two sides, 1oz. copper signal and power planes minimum, UL94V-0, 0.150" (3.8 mm) pcb thickness

Impedance: 65 Ohms nominal on all signal lines, non-loaded pcb

Termination: None provided

Decoupling: SMT decoupling per PICMG 2.0 R2.1

Rear shrouds: Extended 16mm tails and AB compatible shrouds on P3 – P5

DC distribution: Screw terminals for +5, +3.3, return and V I/O (35A rating per terminal), 20 position ATX for +5, +3.3, +/-12VDC, and return (9A rating per pin), 0.250 spade terminals for +/-12Vdc (15A rating per terminal), (2) 4-pin auxiliary disk drive connectors (MTA100)

Compliance: PICMG 2.0 R2.1, hot swap compatible per PICMG 2.1

Power†

Option code PS1: T-Frame equipped with a single 350W 6U DIN power supply

Option code PS2: T-Frame equipped with (2) 350W 6U DIN power supplies

Total output: 300W 90 – 105VAC; 350W 105 – 264VAC; all outputs

Operation: When operating dual power supplies, a single supply can be hot-swapped without effecting normal system operation (PS2)

Input: 90 – 264VAC, universal input

Frequency: 47 – 63 Hz

Efficiency: 70% typical (65% min. at 90VAC)

Power factor: 0.99 typical

Input current: 6A maximum

Inrush current: 40A maximum

Hold-up time: 20 ms minimum

DC outputs: +5.0V/40A, +3.3V/25A, +12V/9A, -12V/2A

Output adjust: +/-10% nominal on +5 and +3.3V only

Ripple/Noise: 50mV maximum, all outputs

Load requirement: None required

Remote Sense: All outputs, 250mV maximum compensation

Cooling: 15cfm/ 400lfm minimum airflow required through power supply fins; airflow provided by system fans

Accessibility: DIN power supplies install in cardcage in any two of three power supply slots; (2) front, (1) rear

Cooling††

Airflow: Bottom intake, top exhaust, pressurized; cPCI boards and power supplies are cooled independently

Fans: (3) 130cfm, high pressure tube-axial, 12VDC, one positioned below 8-slot front cPCI cardcage, one below front power slots, and one below rear power slot; (1) 93cfm, tube-axial, 12VDC, also evacuates air above front power slots

Adjustment: All fans adjustable for 50% or full speed operation; front panel switch control cPCI cardcage fan, power supply fan speeds are controlled by switch (SW2) on the power backplane

Storage

Peripheral Support: (1) 3.5" x 1" device

Power harness: (1) 4-pin IDC, AMP 1-480424-0 or equivalent; (1) 4-pin IE (mini), AMP 171822-4 or equivalent; connects to backplane

Cooling: Convection

Accessibility: Rear removable tray, tool accessible

Control and Input

Switches: **Front Panel:** margin control for +5, +3.3VDC, voltage select (rotary); Voltage/ °C, fan speed control (pushbutton, latching); reset control (pushbutton, momentary)
Rear panel: power supply disable/ inhibit control (SW1), power supply fan speed (50% or full; SW2), AC power switch (rocker), AC circuit breaker (pushbutton, latching)

Power input: Rear panel AC inlet connector (IEC320), detachable line cord

Circuit Protection: Rear panel single pole magnetic circuit breaker 12A (pushbutton, latching)

Monitoring

Interface: Two front panel LCD numeric displays and LED indicators

Functions: Backplane DC voltage and current measurement for +5, +3.3, +/-12VDC (front panel, user selectable); Exhaust air temperature over front cPCI card slots (°C, user selectable, rear access slide probe); Margin control provides +/-10% adjustment of +5 and +3.3VDC (front panel, user selectable); Backplane reset control and indicator (referenced to backplane BRST*); Power-on LED indicator (referenced to +5VDC)

Outputs: DC voltage/current output displayed on (2) front panel green LCDs; Exhaust air temperature display on Voltage LCD when Voltage/°C switch is depressed; Power-on LED indicator illuminates green when power supply +5VDC present; Margin controlled voltages display on Voltage LCD when Voltage selector is set to +5 or +3.3VDC; Reset LED illuminates red when backplane reset (BRST*) is asserted

Tolerance: DC voltage measurement within 1%; current measurement within 3%; temperature within 3°C (Tolerances assume a 20-minute warm-up period for system and installed components)

Environmental

Temperature: 0 – 50°C operating with specified airflow; -20 – 70°C non-operating

Shock/Vibration: Basic transportation per ASTM 0775

Humidity: 5 – 95% non-condensing at 40°C operating, 0 – 95% non-operating

Acoustic: <55 dBA maximum, measured 1 meter from all surfaces

Agency Compliance†††

Safety/Emissions: Available for power supply only. Consult factory for details

Warranty

1 year limited warranty

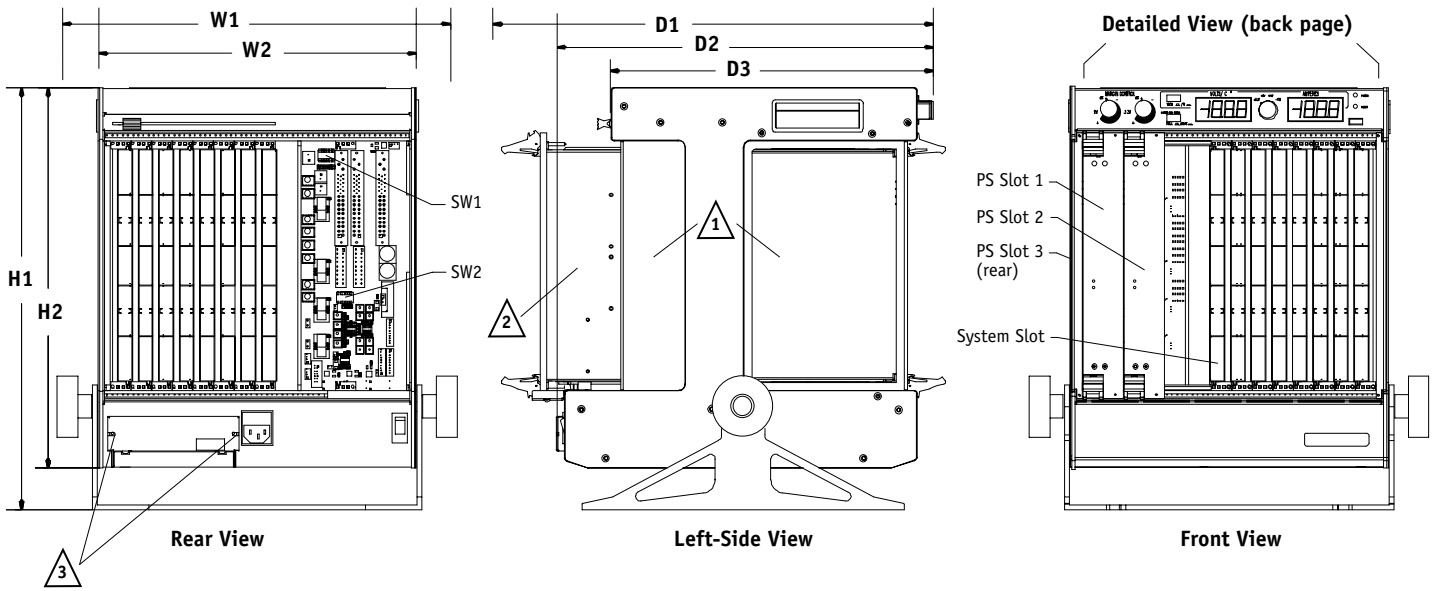

Power Supply Configuration

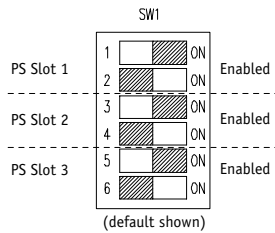

Power Supply Fan Speed

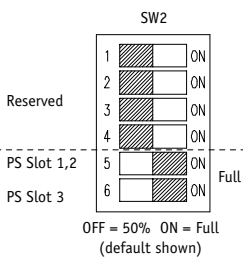

Rear Subrack Adjustment

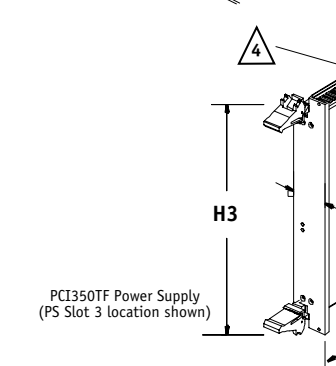
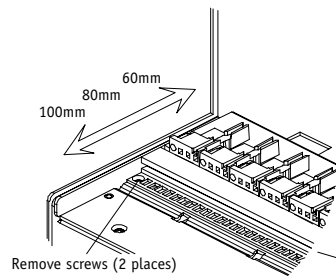

Rear View (side covers removed)

Dimensions:

D1: 17.10" (435 mm)	W1: 15.08" (383 mm)	H1: 16.37" (416 mm)
D2: 14.62" (371 mm)	W2: 12.34" (313mm)	H2: 14.77" (375 mm)
D3: 12.55" (319 mm)	W3: 1.60" (41 mm)	H2: 10.31" (262 mm)
D4: 6.77" (172 mm)		

NOTES:

- 1 Removeable side covers installed (4 places)
- 2 Power supply shown in PS Slot 3 position
- 3 Storage bay removes with 2 screws
- 4 CAUTION!! Power supplies carry hazardous voltage

Detailed View of Front Panel

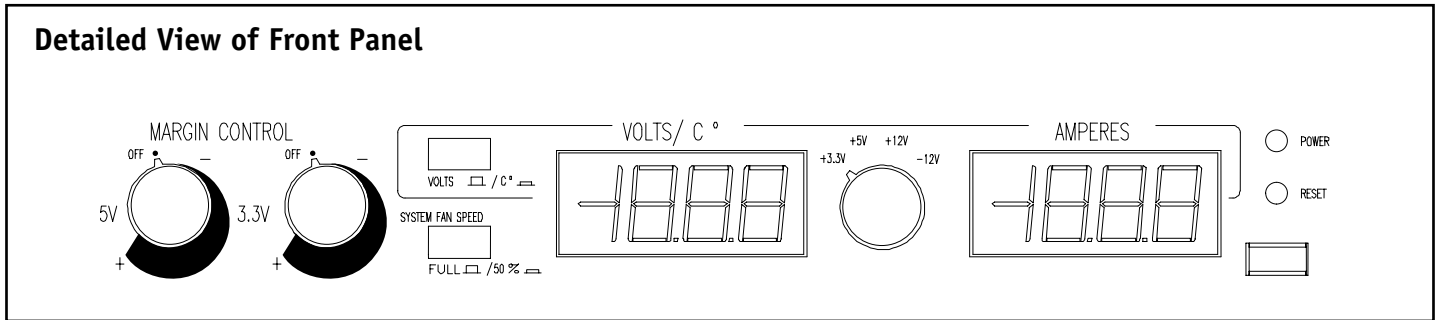

Ordering Information

The T-Frame™ for CompactPCI includes chassis, backplane, power supply, storage bay, and monitoring, and is available in the following standard configurations:

Part number	Description
580-6001-F00-00	T-Frame for CompactPCI with 32/64 bit hot-swap backplane and single 350 AC power supply (PS1)
580-6002-F00-00	T-Frame for CompactPCI with 32/64 bit hot-swap backplane and dual 350 AC power supplies (PS2)

Accessories

014-6001-001-0P	Shielded single-slot filler panel, 6U X 4T; installs in vacant slots
106-1001-099-01	Non-shielded single-slot filler panel, 6U X 4T; installs in vacant slots
110-1171-099-01	Subrack air block, single slot; snaps into a vacant slot to block airflow
2BPCI350AC02-A0	PCI350TF 6U DIN power supply

Notes

- † Designed to operate with a maximum of (2) Tracewell Power PCI350TF power supplies, totaling 700 watts
- †† IMPORTANT all fans must be operated in full speed setting for output power levels greater than 100 watts
- ††† As an option, Tracewell Systems can evaluate agency compliance for the customer's specific integrated product. Consult factory for more details

visit our website at:
www.tracewellsystems.com
or call toll free: 1.800.848.4525