

Tracewell S42 for VXS/V64x

Ultra-lightweight Rugged Performance System Platform

Description

The Tracewell S42 is an ultra-performance computing platform for rugged applications requiring small size and extreme low weight. Using advanced laser manufacturing, high-density power, and differential backplane technology, the S42 is able to deliver unparalleled performance for air or ground-mobile applications.

Weighing just 45 lbs. with 4500W of power and a 21-slot VXS backplane, the S42 incorporates Tracewell's advanced "Light Rigid Core Enclosure Structure". The LRCES™ process utilizes advanced laser weld manufacturing techniques to produce a highly rigid lightweight structure while maintaining the design flexibility of conventional sheet metal. The result is an exceptionally light and rigid platform that is capable of withstanding 30Gs and meets MIL-STD-461 shielding requirements. The Tracewell-designed modular power system is MIL-STD-704 compatible. Each of up to five 900W power modules plugs directly into the backplane, eliminating cabling and providing excellent dynamic current performance. The S42 is available with a VXS (VITA 41) backplane that has been optimized and simulated for speeds up to 10 Gb/s. Precision design, low-loss PCB material, and back-drilling have all been incorporated in order to achieve these speeds. Other backplane options are also available, including VME64x. The cooling system provides sufficient airflow to cool more than 200W per slot at sea level with a 50°C inlet air temperature. Even at an altitude of 10,000 feet the system can cool more than 85W per slot. In low temperature environments, an Ethernet-based health monitor automatically manages start-up down to -40°C. This monitor further provides remote power control and real-time power, cooling, and temperature status.

The S42 from Tracewell Systems delivers innovative design, high-power, and exceptional performance, all in a highly adaptive, lightweight, rugged package.



Features

- Rugged ultra-low weight at just 45 lbs.
- 4500W power is MIL-STD-704 compatible
- EMI shielded per MIL-STD-461
- VXS backplane option supports over 6.25Gb/s
- Managed low temperature start to -40°C
- 200W+/slot at sea level, 85W+/slot at 10,000 ft
- Ethernet monitoring for power and cooling
- Remote power management
- Shock and vibe per MIL-STD-810 and DO-160
- Patent-pending LRCES™ technology

Physical

Construction: Light Rigid Core Enclosure Construction™; Aluminum sheet, 5052-H32 alloy; Aluminum Extrusion, 6101-T6 alloy
Cardguides: 94V-0 flame rated material
Cardcage: Top Load 6U x 160mm, IEEE 1101.10, P0/J2; supports rear J2 overlays up to 18 slots (i.e. DLK); no RTM support
Dimensions: 15.8”D (402mm), 17.5”W (445mm), 19.00”W
Weight: 45 lbs. (20.5 kg)
Finish: Textured paint, black; all exterior surfaces, except rack flanges and honeycomb; all other aluminum is brushed gold chromate per MIL-STD 5541
Rack-slides: 1 pair Jonathan #145 QDP-22 (installed)
Other: (2) rear shock pin receivers; (8) captive 10-32 retainer thumbscrews for EIA mounting; removable top and bottom covers

Backplane

General: (B1) BP, VME64x, 21-slot, J1/J2/P0
 (B2) BP, VXS, 21-slot, DS, J1/J2/P0
Bus structure: (B1/B2) VME64x 32/64 bit, J1/J2 monolithic; (B2) adds dual switch VXS optimized for 6.25Gb/s
Connectors: (B1/B2) 160 pin, 5 row, J1/J2, IEC 61076-4-113 133 pin, 7 row, J0, IEC 61076-4-101
 (B2) J0 payload and J1 - J5 switch, Tyco Multigig, JPWR1 switch, Positronic PWR-6P-V15
Assembly: SMT/ press-fit assembly
Layer count: (B1) 10 layers, (B2) 22 layers
PCB: all-stripline, UL94V-0, (B1) FR-4, (B2) low-loss IS620, backdrilled
Termination: Passive, 330/470 Ohm
Decoupling: High-freq. decoupling at each slot; 0.1µF MCL ceramics (SMT) Low-freq. decoupling distributed across the backplane; 100µF Tantalum (SMT)
Rear shrouds: Extended tails/shrouds on all J2 and J0 V64x slots
Compliance: (B1/B2) ANSI/VITA 1.1-1997
 (B2) ANSI/VITA 41.0

Power

General: Supports up to 5 modular 900W plug-in power supplies; each power supply provides +5, +3.3, +/-12V, and 5V standby; power supplies plug-in from bottom of chassis
Total output: (PS1) 2700W (w/ 3 power supplies; min. config.)
 (PS2) 3800W (w/ 4 power supplies)
 (PS3) 4500W (w/ 5 power supplies)
Input: 250 - 280VDC
Efficiency: 80% or greater
Input current: 4.2A at 270VDC (per ps)
Inrush current: 20A max. at 270VDC (soft start)
Hold-up time: 20 ms minimum
DC outputs: +5V/80A, +3.3V/80A, +/-12V/20A (current ratings per power supply); 12V output of one power supply is always dedicated to fan power
Cooling: Independent power supply cooling provided
Other: MIL-STD 704F compliant power input

Cooling

General: Two rear plug-in fan modules; the upper module cools the board slots (4 fans), the lower module cools the power supplies (2 fans); honeycomb inlet and exhaust EMI filters
Airflow: Front intake, rear exhaust, evacuated
Fans: 150 CFM, high-pressure tube-axial, +12VDC
Control: Temperature speed control with pre-heaters
Performance: 200W+ per slot at sea level, 85W+ per slot at 10,000 ft; assuming a full compliment of 21 boards at 0.16” H₂O total static pressure, the system can provide 17.7 CFM per slot
Accessibility: Fan modules are rear removable, tool accessible

Control and Input

Switches: Power on/standby (soft-switch control via Ethernet)
Power input: Rear panel MIL circular connector (#MS3102A16-10P); no line cord provided
Circuit Protection: Internal 10A fuse on input of each power supply

Monitoring

General: Ethernet-based independent system monitor provides system status and control
Interface: Front panel tricolor LED indicators and RJ-45 Ethernet connector
Functions: Backplane voltage (+3.3,+5,+12,-12Vdc,+5Vsb); actual values and fault condition if out of tolerance
 Input voltage; actual value and fault condition if input voltage not detected or out of tolerance
 Fan speed (6 fans); actual fan speeds and fault condition if any fan falls below 25% rated RPM
 (1) inlet and (2) exhaust temperature sensors; actual temperatures and fault condition if temperature exceeds 60°C
Outputs: Power on/inhibit control of power supplies
 LED indicators for Input Power, Fans, Temperature and Power Supplies (good=green, red=fail); Ethernet interface provides alert status and individual values of all monitored elements
Low temperature: Software control will preheat and start fans down to -40°C; system can be programmed to apply backplane power at any specific temperature to match temperature requirements of installed boards

Environmental

Temperature: -40°C to +50°C operating; -45°C to +71°C non-operating
Altitude: -1300 - 10,400 ft. operating; 41,000 ft. non-op.
Shock/Vibe: MIL-STD-810F methods 513.5 proc. I - III, 516.5 proc. V; DO-160D section 8, category R
EMC: MIL-STD-461E
Humidity: 4 - 95% non-condensing
Acoustic: <60 dBA maximum (1 meter)

Note: All environmental specifications are design to meet

Warranty

1 year limited warranty

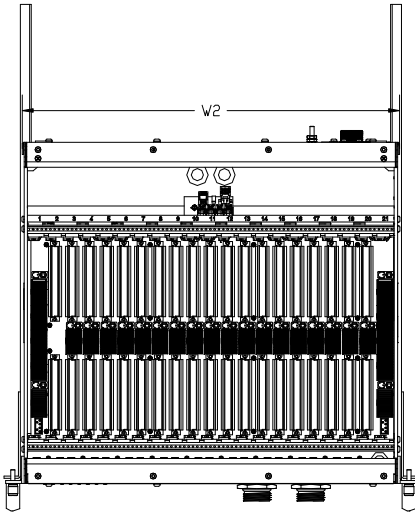

TOP VIEW (COVER REMOVED, B2 SHOWN)

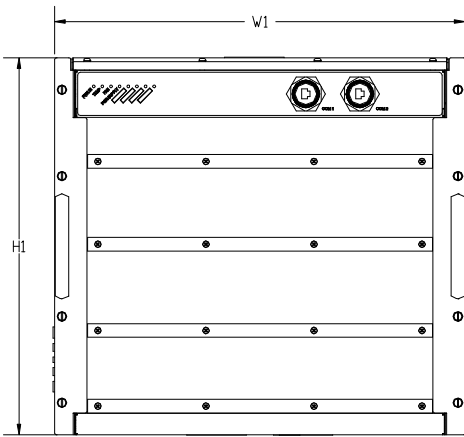
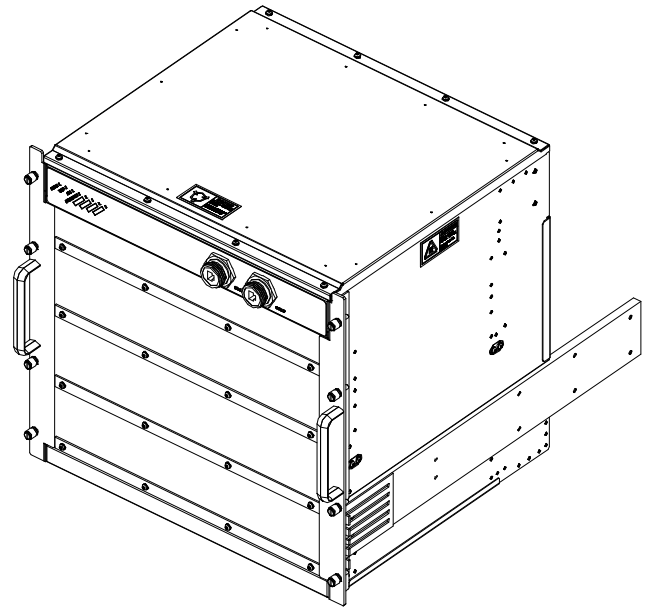

FRONT VIEW

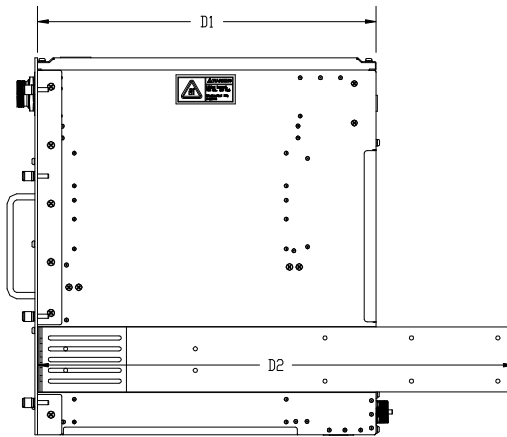

RIGHT SIDE VIEW

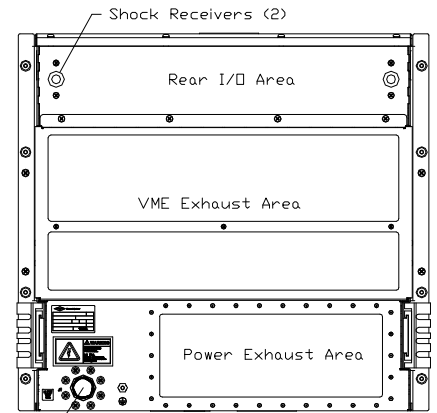

REAR VIEW

Dimensions:		
D1: 15.70" (399 mm)	W1: 19.00" (483 mm)	H1: 17.47" (444 mm, 10U)
D2: 22.10" (561 mm)	W2: 17.50" (445 mm)	

Notes
⚠ Do not block air intake or exhaust panels

Ordering Information:

The Tracewell S42 for VXS/V64x is available in the following configurations (consult factory for additional versions and options):

Part Number	Description
542-6XXX-FXX-XX	S42-10U, VXS 21sl, 4500W, ME
542-6XXX-FXX-XX	S42-10U, VME64x 21sl, 4500W, ME

Notes:

1) Tracewell provides many additional program services such as thermal simulation, safety and EMC certification, HALT/HASS testing. Consult factory for more details.

request a quote at our web site:
www.tracewellsystems.com
or call: 1.800.848.4525

© Copyright Tracewell Systems, Inc. 2006

Tracewell Systems, Inc. reserves the right to make changes without notice.
All brand or product names may be trademarks or registered trademarks of their respective holders.
Please consult Tracewell Systems for any special or custom requirements.

S42-DS-060313

