

# E-Tool 14 Drawer Mobile Manager (Managed)



## Description

The Tracewell E-Tool Mobile Manager is the answer to Defense and Commercial Industries' initiative to implement and field electronic media platforms tools reducing the reliance on traditional paper bound manuals, Interactive Electronic Tech Manuals IETM. Tracewell Systems' objective is to provide a storage, transport and charging system with a single point LAN connection for a wide variety of E-Tool platforms that is lightweight and rugged, enabling worldwide use and operation in harsh environments.

## Features

- Charges up to 14 Laptop Computers Simultaneously
- Network Connections and Power Provided to Each Tray
- Secures E-Tools for Transport
- Managed Ethernet Switch

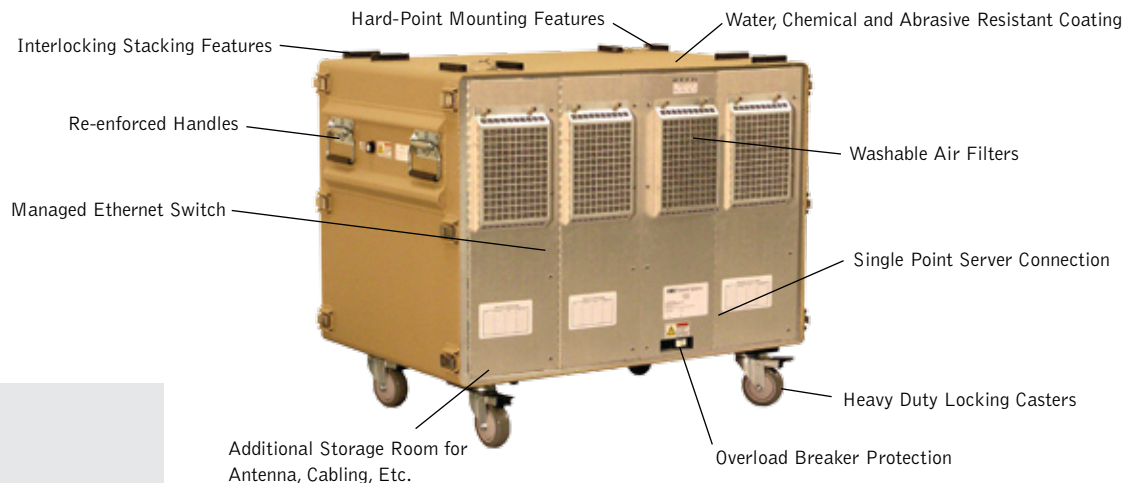

## Description

E-Tool Mobile Manager,  
14 Drawer, Managed

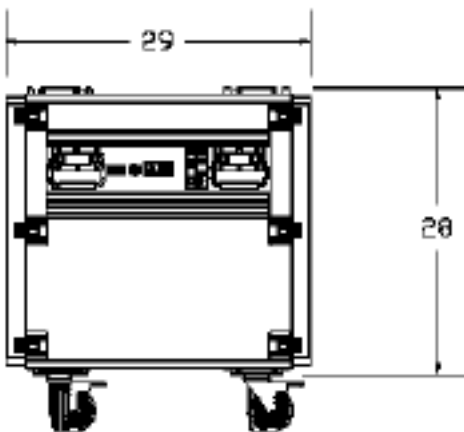
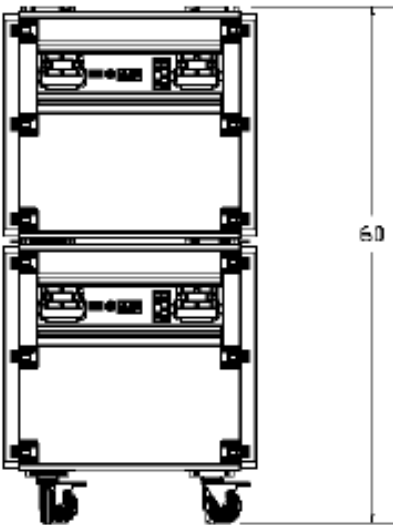
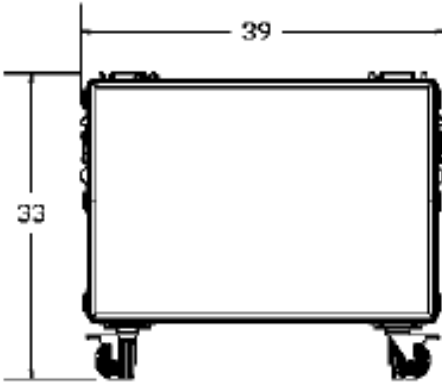
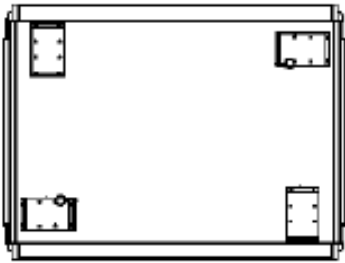

## Specifications

- Operating Temperature: 0C - +50C
- Dimensions: Without Casters (H) 28" (W) 39" (L) 29"  
29" With Casters (H) 33" (W) 39" (L) 29"
- Universal Input Power: 90-264 VAC, 47-440Hz, 15A Max, Single Phase
- Rugged Enclosure Design incorporates, spring loaded recessed handles and rugged, abrasion & corrosive resistant coating
- Unit equipped with a managed Ethernet switch
- Weight: approx. 210lbs (empty)

## System Monitors

- Fan Fail
- Fan Speed
- Temperature
- Input Power
- Current Draw

## Rack System

- 14 E-Tool charging/LAN interface trays
- Variable speed fans provide cooling to each tray
- Pre-wired for CAT 5
- Washable air filters

## Power System

- Surge protected, conditioned power
- Over-temperature shutdown
- Universal AC input voltages are converted to filtered and regulated 115V/60Hz AC powering each tray

## Common Rugged Docking Trays: (14)

- 11" clearance when fully extended
- Tray Dimensions: (L)16.4" (W)15" (H)3.25"
- Open provide easy access to E-Tools
- Single point locking mechanism locks all drawers
- Adjustable & secure strapping systems secures E-Tools for shipment

© 2011 Tracewell Systems, Inc. All rights reserved.

Tracewell Systems, Inc. reserves the right to make changes without notice. All brand or product names may be trademarks or registered trademarks of their respective holders. Please consult Tracewell Systems for any special or custom requirements.